



SB-2292SG



Line	MONSTER LINE
Application	CAR AIRPLANE
Servo Size	Standard
Operating Voltage	6.0V-8.4V
Speed	0.055 s/60°
Torque	50 kg/cm 694.4 oz/in
Amplifier Type	Digital Controller
Motor Type	Patented Brushless
Case Type	Aluminum
Protection	Water Resistant
Dimensions (L x W x H)	40.3 x 20.2 x 38.7 mm
Weight	79 g
Gear Type	Specialized Steel

DIMENSIONS

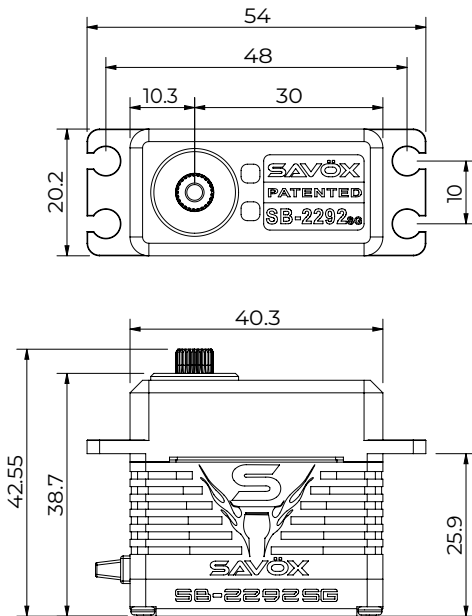

PERFORMANCE RADAR

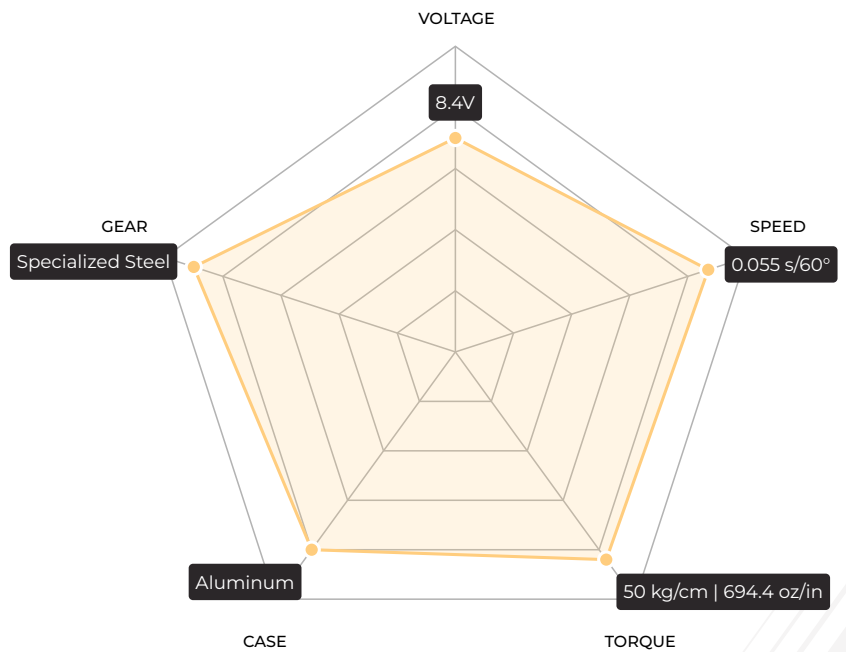

DETAILED SPECIFICATION

Compability	Normal	Potentiometer	VR
Speed @6.0V	0.085 s/60°	Cable	22 AWG 300 ±5 mm
Torque @6.0V	27 kg/cm 374.9 oz/in	Connector	JR Connector
Speed @7.4V	0.07 s/60°	Stall Current @6.0V	7200 mA
Torque @7.4V	36 kg/cm 499.9 oz/in	Operating Current @6.0V	200 mA
Speed @8.4V	0.055 s/60°	Stall Current @7.4V	9200 mA
Torque @8.4V	50 kg/cm 694.4 oz/in	Operating Current @7.4V	220 mA
PCB Board	12-bit	Stall Current @8.4V	10500 mA
Rotating Direction	Counterclockwise (when 1000→2000 µsec)	Operating Current @8.4V	250 mA
Max Travel	~130° (when 900→2100 µsec)	Idle Current	5 mA
Operating Travel	100° (when 1000→2000 µsec)	Dead Band Width	3-5 µsec
Neutral Position	1500 µsec	Frequency Range	50-360 Hz
Horn Gear Spline	25T(Φ6)	Control System	Pulse width modification
Bearing	3x Ball Bearings	Operating Temperature	-10°C to 50°C